

Open Headstock Pipe Spool Welding Station High Efficiency Pipe Welding System

Basic Information

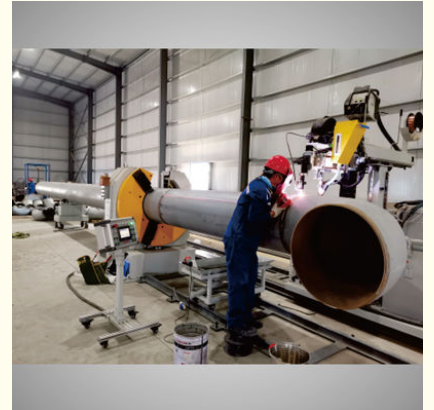

Product Specification

- Control: PLC+touch Screen+remote Pendant Centralised Control
- Model: KB370T,KB630TMS,KB500TMS
- Highlight: **Open Headstock Pipe Spool Welding, High Efficiency Pipe Spool Welding, High Efficiency pipe welding system**



More Images



Product Description

Open Headstock Pipe Spool Welding Station

Single station or integrated into production lines Suitable for welding pipe-pipe, pipe-flange, pipe-elbow, pipe-dish end, pipe-tee Able to do root pass, filling, capping according to different welding processes TIG, Achieve hot wire TIG, cold wire TIG, MAG, SAW, narrow groove TIG/SAW welding Easy operation, simple training Highest welding efficiency, lowest requirement of operating skill Most convenient for material loading/unloading (Open head design for easy handling)



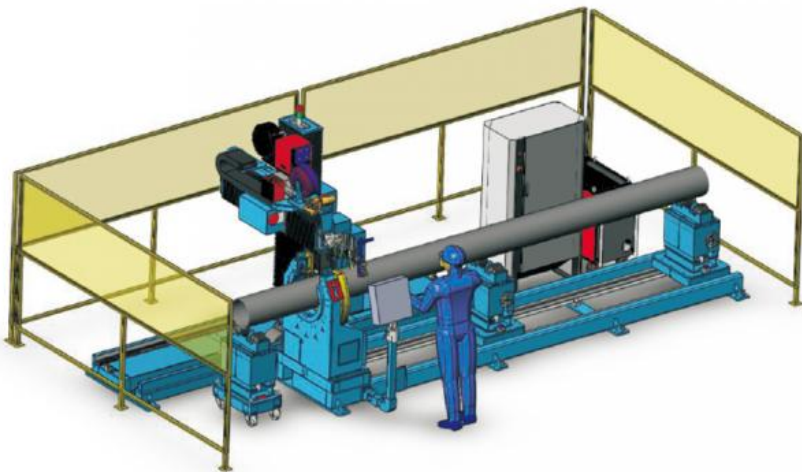



+86 13962665533



huaheng1995@gmail.com



huahengautomation.com

No.99 WuSongJiang Road, KunShan, JiangSu, PR.China PC.215334